

QUICK RACE TUNING - QRT - CALIBRATED

High Polished Stainless Steel - **AISI 316** - Toggle / Wire Terminal

ART. NO.	THREAD G	PIN	A	B	C	Min - Max	L1	L2	BL/KG	KG/100
QRT19014	1/4"	6,35	8	16	4	139-179	56	169	1300	14,3
QRT19516	5/16"	8,00	10	20	5	173-223	60	201	2200	24,7
QRT19716	7/16"	11,10	15	30	8	223-293	80	257	4600	60,7

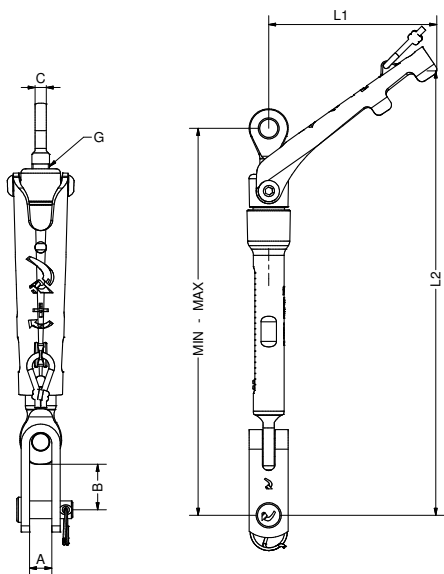

RIGGING SCREWS



Community Design Registration 2012
design reg. -002094003-001

QUICK RACE TUNING - QRT - CALIBRATED

High Polished Stainless Steel - **AISI 316** - Toggle / Wire Terminal

ART. NO.	WIRE	THREAD G	PIN	A	B	L1	L2	Min - Max	BL/KG	KG/100
QRT25014	2,5	1/4"	6,35	8	16	52	169	166-206	1000	14,3
QRT03014	3,0	1/4"	6,35	8	16	52	169	172-212	1300	14,6
QRT32014	3,2-1/8"	1/4"	6,35	8	16	52	169	172-212	1300	14,6
QRT04516	4-5/32"	5/16"	8,00	10	20	60	201	201-251	1700	23,9
QRT05516	5-3/16"	5/16"	8,00	10	20	60	201	208-258	2200	24,8
QRT06716	6	7/16"	11,1	15	30	80	257	265-335	4600	60,7
QRT07716	7-9/32"	7/16"	11,1	15	30	80	257	272-342	4600	62,8

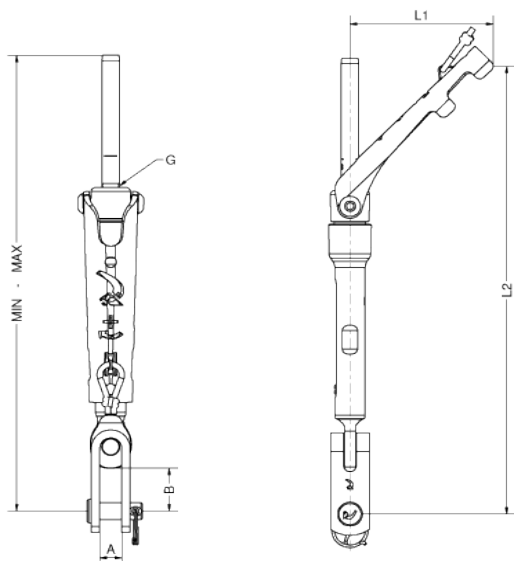

Community Design Registration 2012
design reg. -002094003-001